

Ø 62H8  $\begin{matrix} +0.046 \\ +0.000 \end{matrix}$

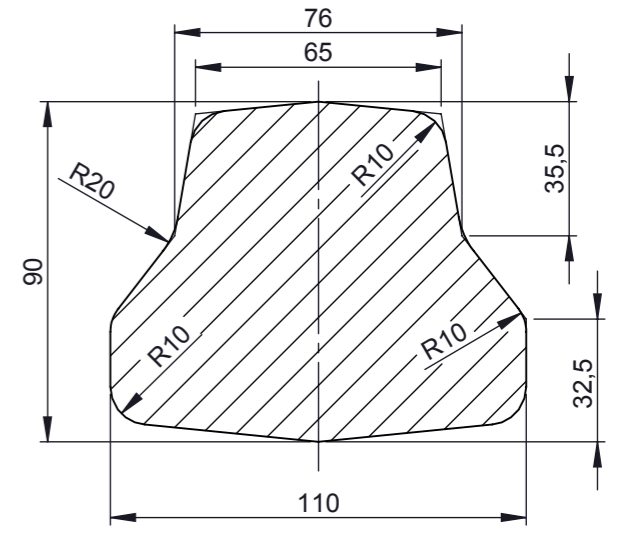

PRESEK A-A  
Razmera 1 : 2

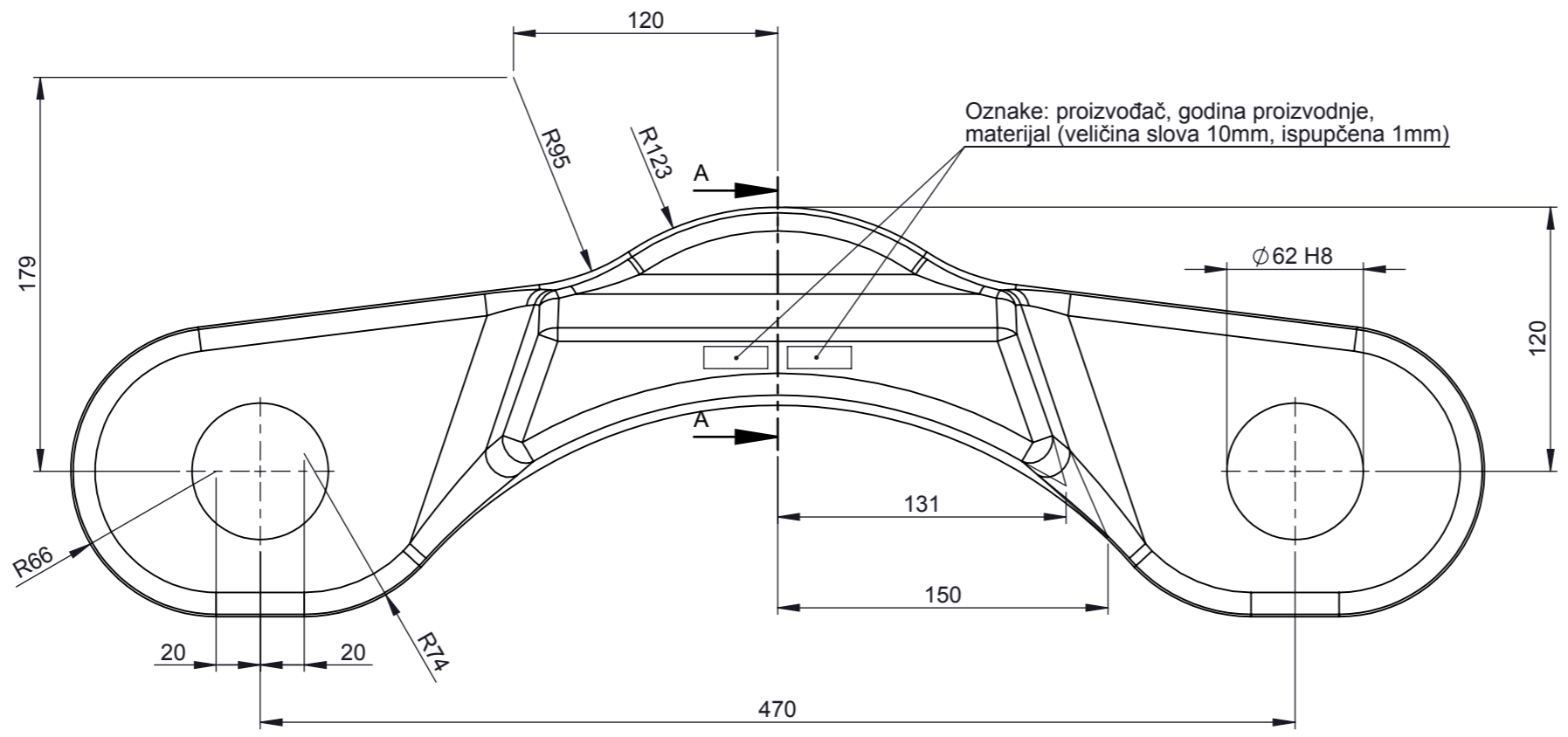
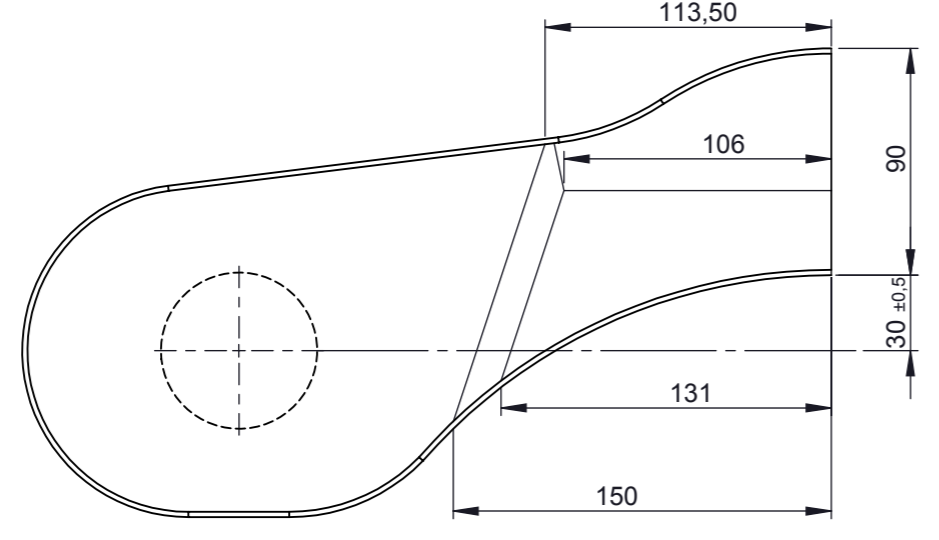
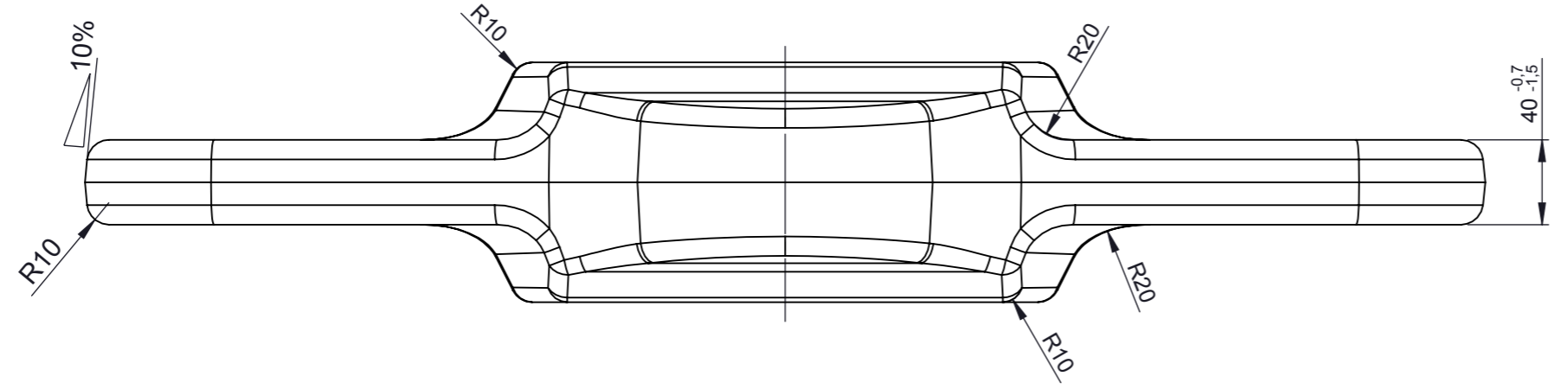

DEO ZA: Delovi kočionog sistema		Termička obrada:			
		Izdav.			
		Datum			
		Razmera 1:3		Težina (kg) 27.1	
		Materijal DIN EN 10025 1.0570 S355J2			
A	1081	02.09.	P.Ž.	Crtao 02.09.	P.Živković
				Konstr. 02.09.	P.Živković
				Odobr.	N.Madžarević
		Naziv <b>KOČIONA SPOJNICA SA PUPKOM</b>			
		Crtež br. Ž02.012.04.777.02			List 01
St. i.	Izmene	Datum	Ime	veza sa: 2FWG000.0.07.031.004	Br. otk. G-3-2568.00
				Zamena za:	

