

Ø 72H8  $\begin{matrix} +0.046 \\ +0.000 \end{matrix}$

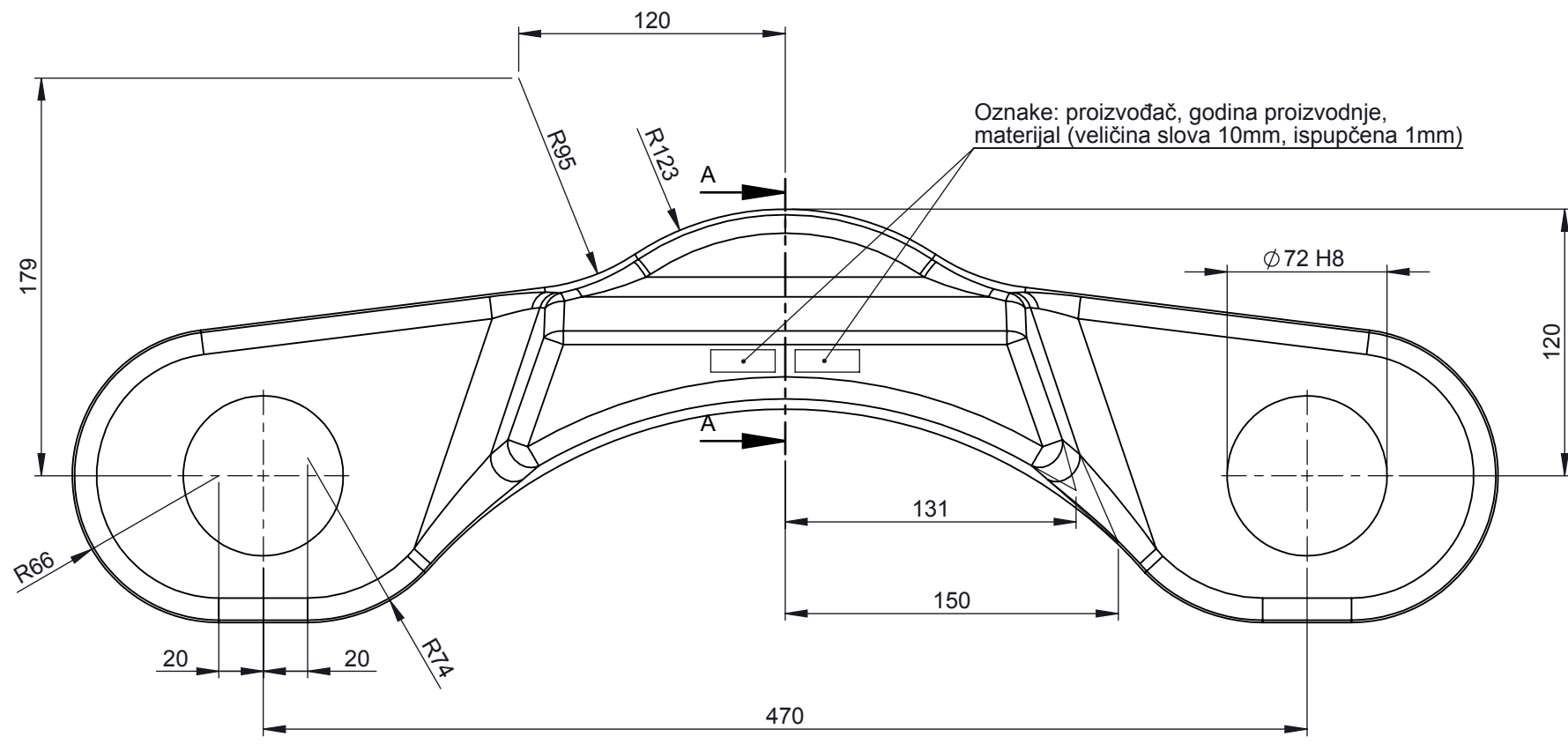

Oznake: proizvođač, godina proizvodnje, materijal (veličina slova 10mm, ispuščena 1mm)

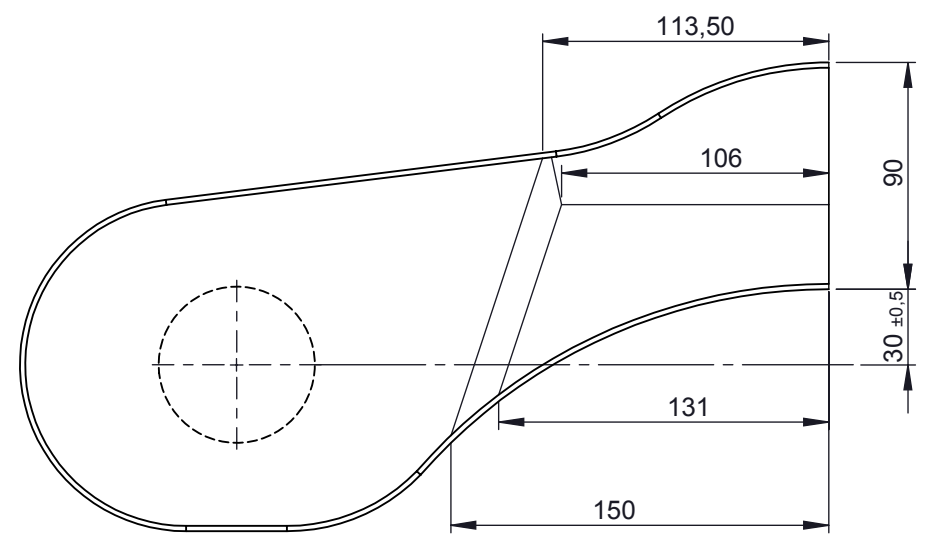
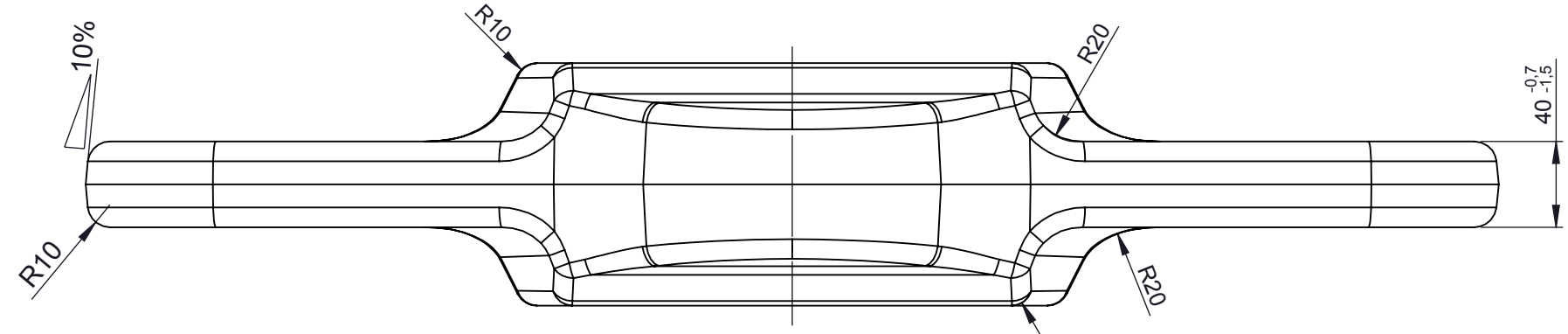
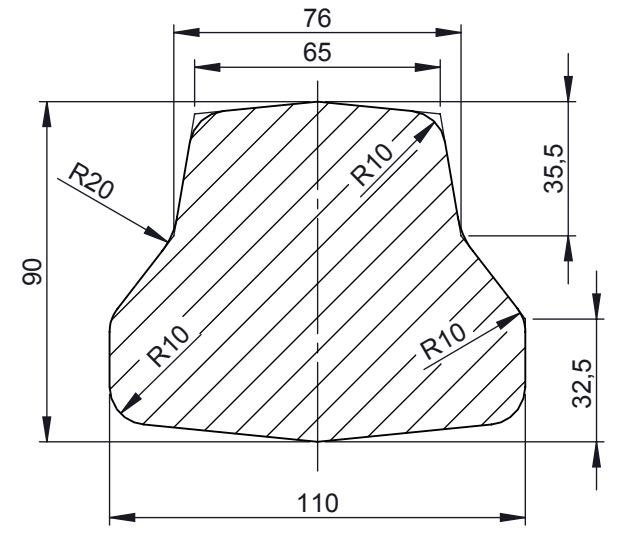

DEO ZA: Delovi kočionog sistema		Termička obrada:		
		Izdav.		
		Datum		
		Razmera	1:3	Težina (kg) 27.1
		Materijal	DIN EN 10025 1.0570 S355J2	
A	1080	02.09.	P.Ž.	Crtao
				02.09.
				P.Živković
				Konstr.
				02.09.
				P.Živković
				Odobr.
				N.Madžarević
		Naziv		
		KOČIONA SPOJNICA SA PUPKOM		
		Crtež br.		
		Ž02.012.04.777.01		
		List		
		01		
St. i.	Izmene	Datum	Ime	veza sa: 2FWG000.0.07.031.004
				Br. otk. G-3-2568.00
				Zamena za:

