

$\varnothing 45H8$	$+0.039$ $+0.000$	✓ / / 1.6 / /

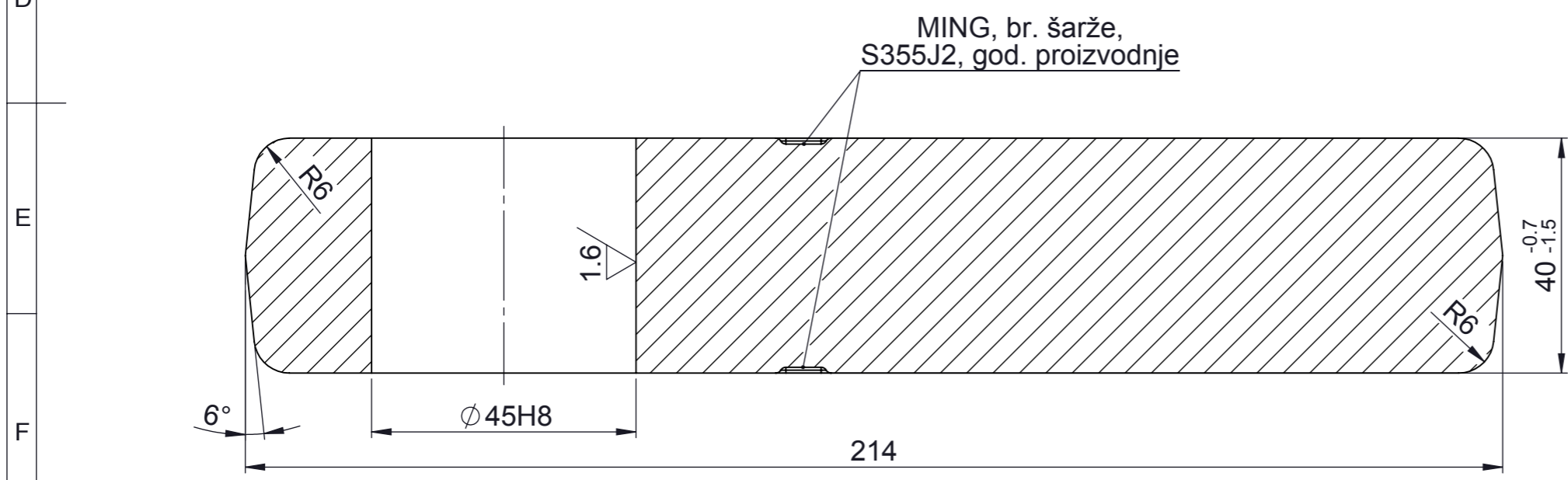

PRESEK A-A

DEO ZA: Delovi kočionog sistema				Termička obrada:		
				Izdav.		
				Datum		
				Razmera	1:1	Težina (kg) 3.2
				Materijal	DIN EN 10025 1.0570 S355J2	
A	1034	02.09.	P.Ž.	Crtao	02.09.	P.Živković
				Konstr.	02.09.	P.Živković
				Odobr.		N.Madžarević
				Naziv		
				GLAVA PARALELOGRAMA S		
				Crtež br.		
				Ž02.012.09.777.01		
				List		
				01		
St. i.	Izmene	Datum	Ime	veza sa: 30680569.5.29.3.1	Br. otk.	G-3-0383
				Zamena za:		

