

Ø 33H8	+0.039	✓ / / 1.6 / /
	+0.000	

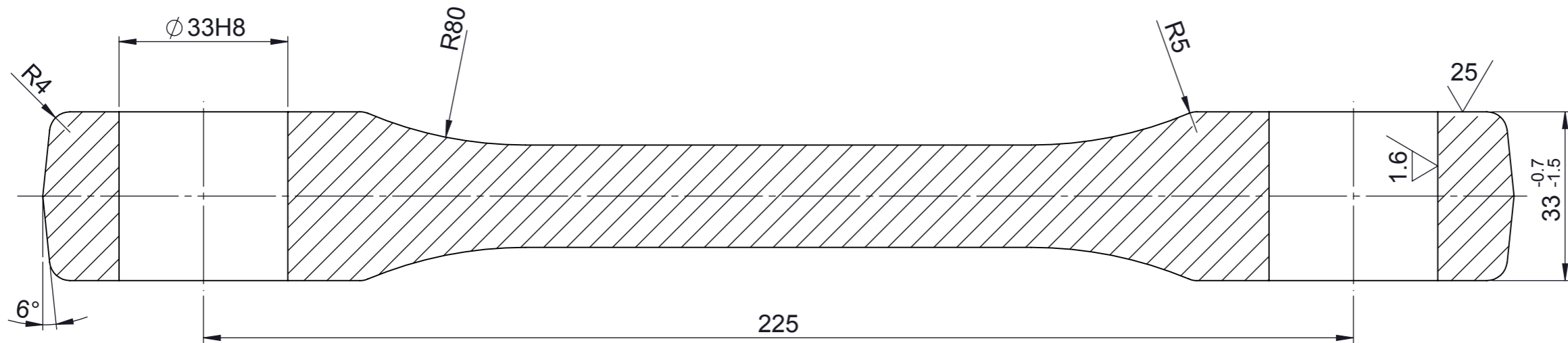

PRESEK A-A

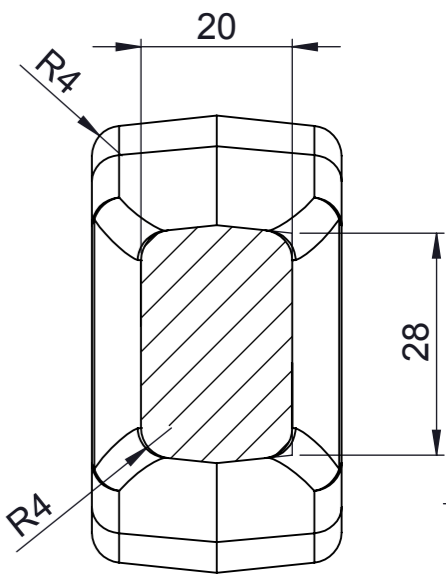

PRESEK B-B

DEO ZA: Delovi kočionog sistema						Termička obrada:	
ISO 2768 - m DIN 8570 - BF						Izdav.	
						Datum	
A 1037 06.07. P.Ž. Crtao 06.07. P.Živković Konstr. 06.07. P.Živković Odobr. N.Madžarević						Razmera 1:1 Težina (kg) 2.12	
						DIN ISO1302	
						Naziv <b>VEŠALICA 225</b> Brake Block Hanger 225	
						Crtež br. Ž02.012.06.777.01	
						List 01	
						L	
St. i. Izmene Datum Ime veza sa:3ELH600.0.07.043.041						Br. otk. G-3-0731 Zamena za:	

