

Ø 50C11	+0.290	✓ / / ✓ / /
	+0.130	
106H11	+0.220	
	+0.000	

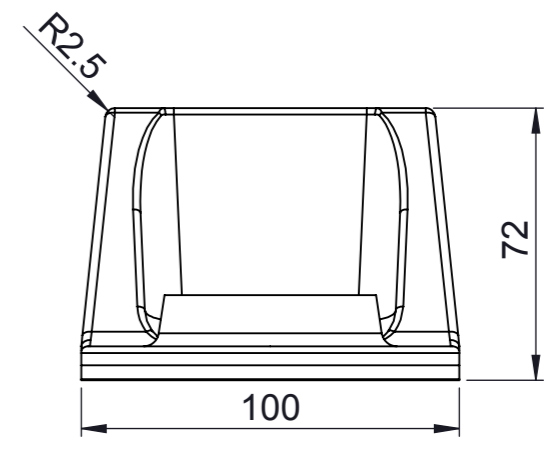

PRESEK A-A

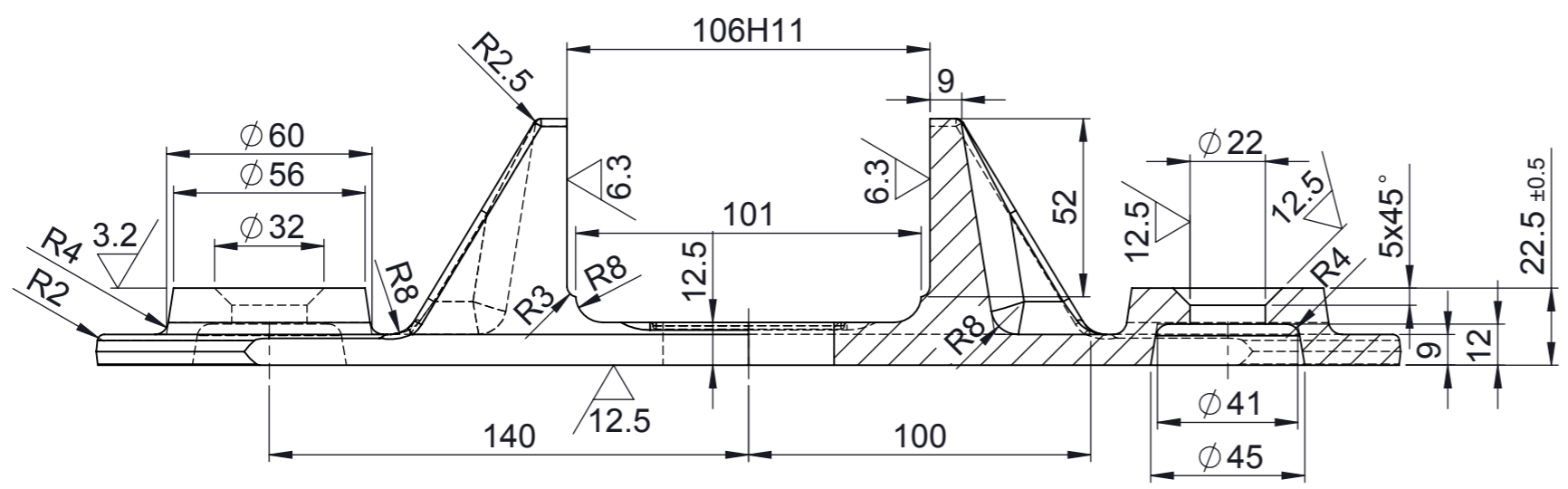
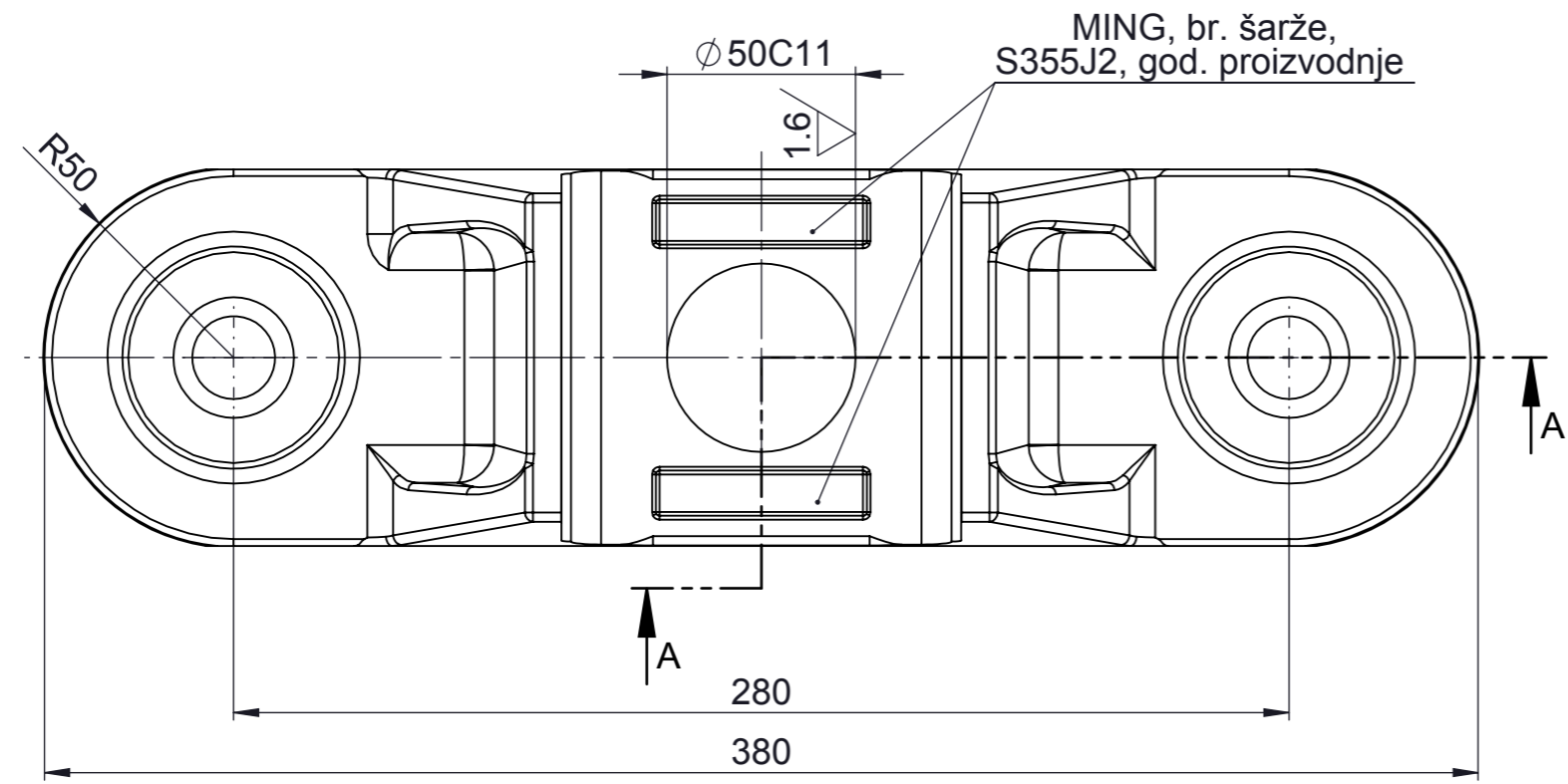

MING, br. šarže, S355J2, god. proizvodnje

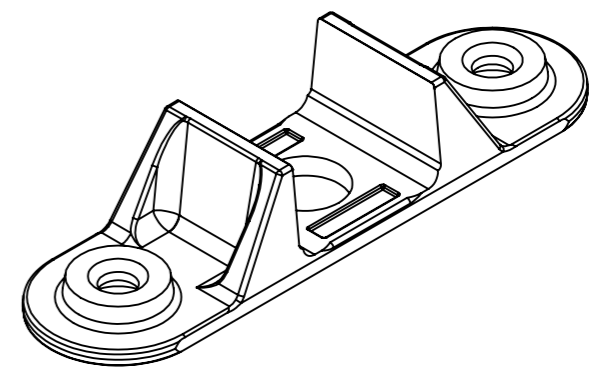

DEO ZA: Delovi gornjeg sklopa				Termička obrada:			
				Izdav.			
				Datum			
				Razmera 1:2		Težina (kg) 4,65	
				Materijal DIN EN 10025 1.0570 S355J2			
A	1030	08.07.	P.Ž.	Crtao	08.07.	P.Živković	Naziv KLIZNICA Stand
				Konstr.	08.07.	P.Živković	
				Odobr.		N.Madžarević	
				Crtež br. Ž02.011.02.777.02		List 01	
St. i.	Izmene	Datum	Ime	veza sa: 10622618.4.8.3.2	Br. otk. G-2-1358	Zamena za:	

