

PRESEK A-A

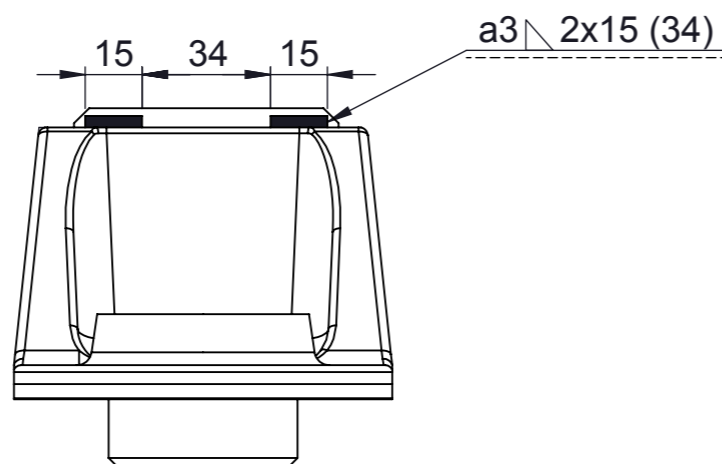

Zavareni spoj:
 - Certifikacioni nivo: EN 15085-2 CL1
 - Klasa izvodjena vara: EN 15085-3 CPC2
 - Klasa kontrole vara: EN 15085-3 CT3
 - Tolerancije položaja i oblika: EN ISO 13920 BF

Poz.	Kom.	Naziv	Br. crteža	Materijal	Standard
5	2	Kružni HV ravni var		E 42 4 B 32 H5	DIN EN 15085-3 (CP2)
4	4	Ravni ugaoni var		E 18 8 Mn R 1 2	DIN EN 15085-3 (CP2)
3	1	ČEP ZA KLIZNICU	Ž02.011.02.555.02	S355J2	DIN EN 10025 1.0570
2	2	PLOČICA ZA KLIZNICU	Ž02.011.02.555.01	X120Mn12	DIN 1.3401
1	1	KLIZNICA	Ž02.011.02.777.01	S355J2	DIN EN 10025 1.0570

DEO ZA:		Naziv		Br. crteža		Materijal		Standard	
DEO ZA:									
Delovi gornjeg sklopa									
		ISO 2768 - m		DIN 8570 - BF		DIN ISO1302			
						Termička obrada:			
						Izdav.			
						Datum			
						Razmera		1:2	
						Težina (kg)		5,47	
						Materijal		DIN EN 10025 1.0570 S355J2	
A	1032	08.07.	P.Ž.	Crtao	08.07.	P.Živković	Naziv		
				Konstr.	08.07.	P.Živković	KLIZNICA - sklop Stand - compl.		
				Odobr.		N.Madžarević			
						Crtež br.		Ž02.011.02.999.01	
						List		01	
						L			
St. i.	Izmene	Datum	Ime	veza sa:FWG106.0.04.082.016	Br. otk.	G-2-1358	Zamena za:		

